

REVISIONS			
REV	DESCRIPTION	DATE	APPROVED

QC.
DT.

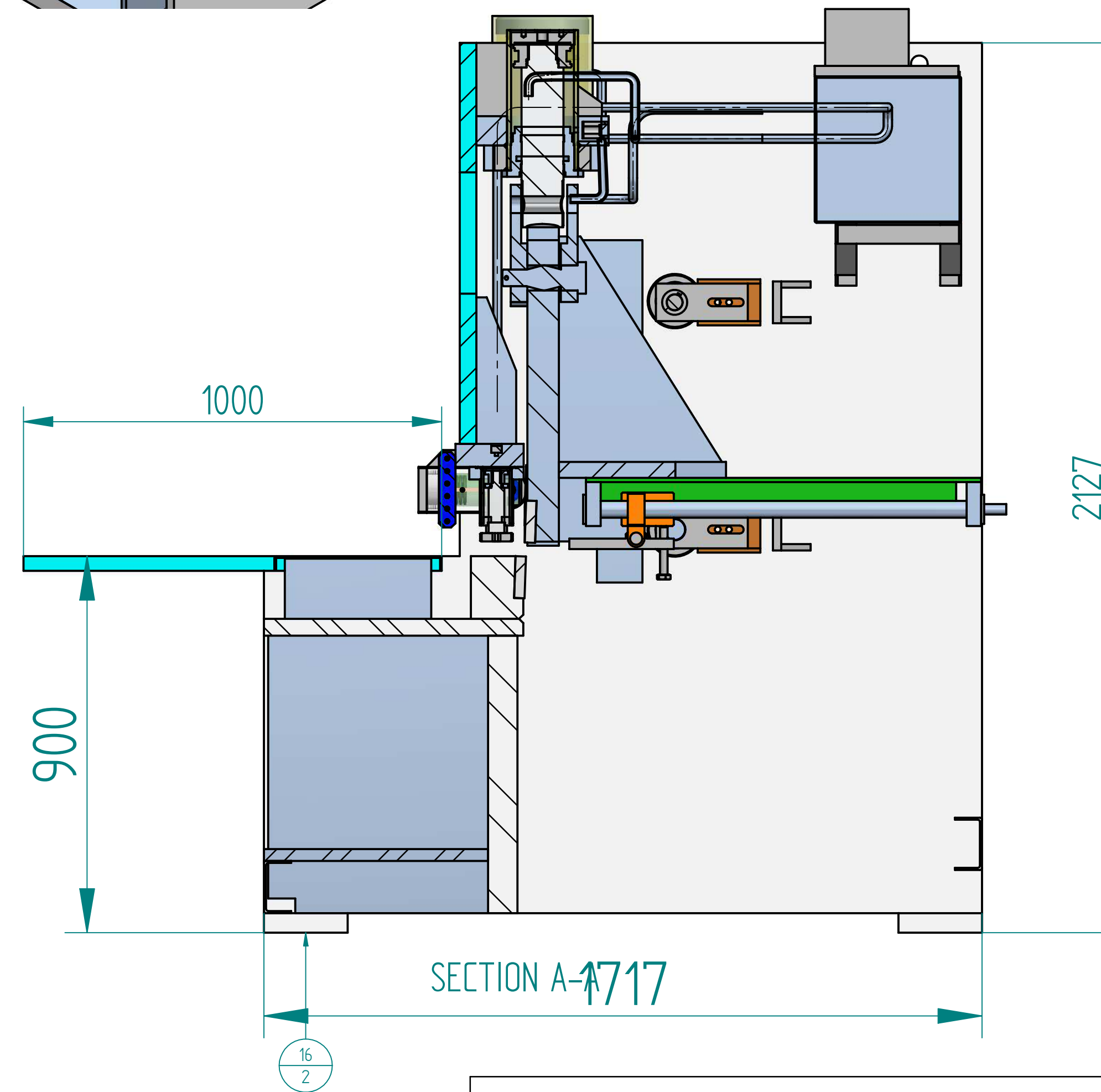

Shearing machine 2500x12mm		
1	MODEL	MHPL1225
2	PLATE S THICKNESS (mm)	12
3	rack angle	2
4	length of cut (mm)	2500
5	back gauge travel (mm)	750
6	motor (HP)	25
7	hyd oil tank (liter)	300
8	length (mm)	3025
9	width	1717
10	height	2127
11	working height	900
12	strokes per minute as full length	12
13	no of holding cylinder	12
14	number of front sheet supports.	4
15	length of squaring arm.	1000
16	weigh approx (mt)	9
17	working pressure (kg ² cm)	210
18	cylinder 1 bore	150
19	cylinder 1 tonnage	37
20	cylinder 2 bore	220
21	cylinder 2 tonnage	79
22	clamping cylinder bore	70
23	clamping cylinder tonnage	8

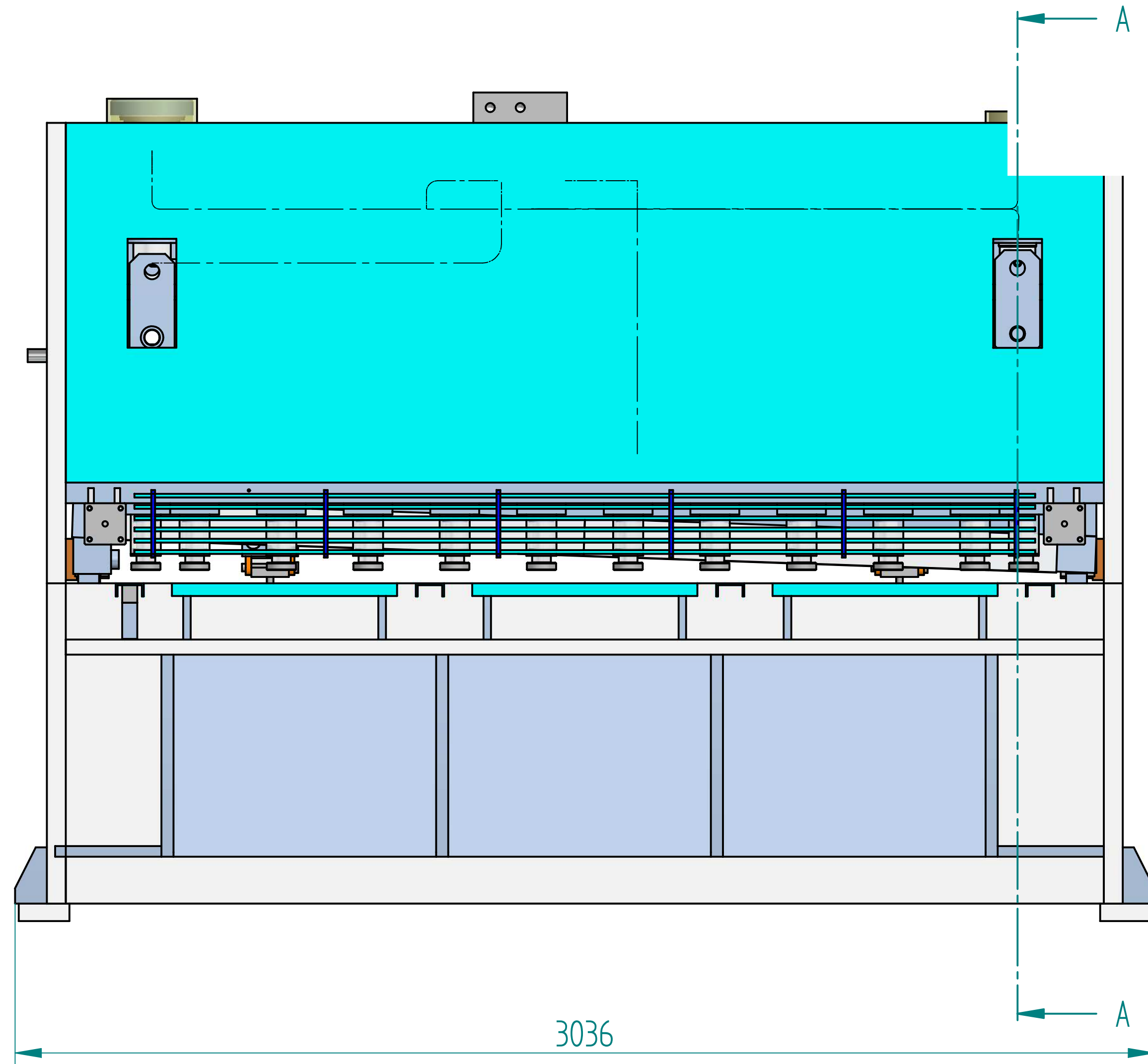
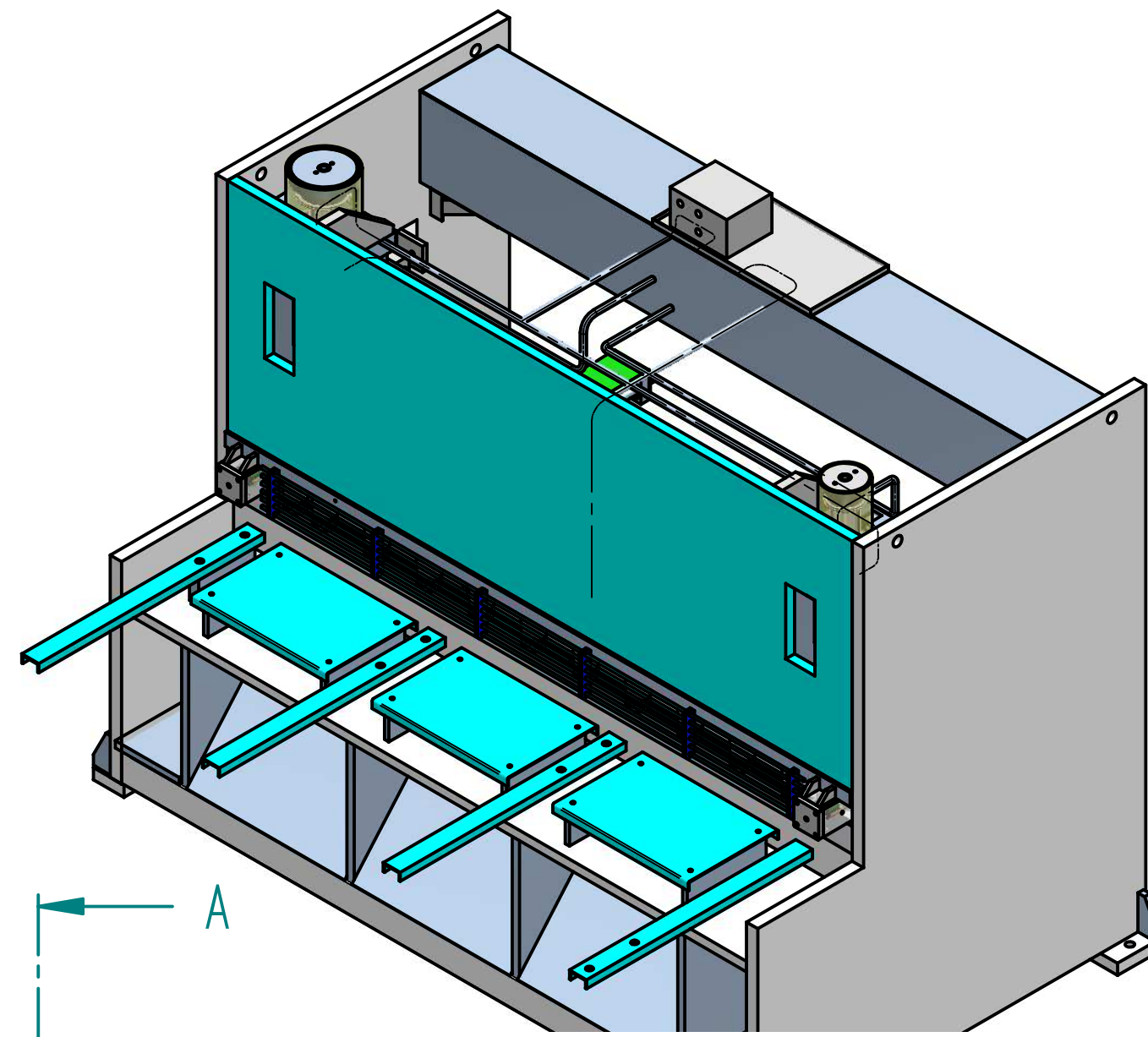
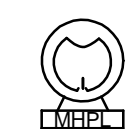

MICRO HYDROTECHNIC PVT . LTD

LINEAR DIMENSIONS			JOB NO :-	TITLE:- 2500x12mm
0	TO 10	±0.05		
10	TO 30	±0.10		
30	TO 100	±0.15	CHKD BY:-	Q.C. :-
100	TO 300	±0.20		
300	TO 1000	±0.25	RETURN DATE :-	DRAWING NO:-
1000	TO 2000	±0.50		
SCALE. NTS.			ISSUE DATE :-	QTY:- 00 MARTIAL:- MS